

(VC)-TCXO-Oscillator SMD (VC)-TCXO5032T3.3 3.3V CMOS/TTL

- Voltage Control Temperature Compensated Crystal Oscillator
- SMD in ceramic case (5.0 x 3.2 x 1.2) mm
- CMOS/TTL Square Wave Output; Wave form code is " T "
- on Tape & Reel
- RoHS conform; Lead-free product
- Vibration: MIL-STD-202F method 204, 35G, 50 to 2000 Hz
- Shock: MIL-STD-202F method 213B, test cond. E, 1000GG 1/2 sine wave
- Available in many standard and special frequencies

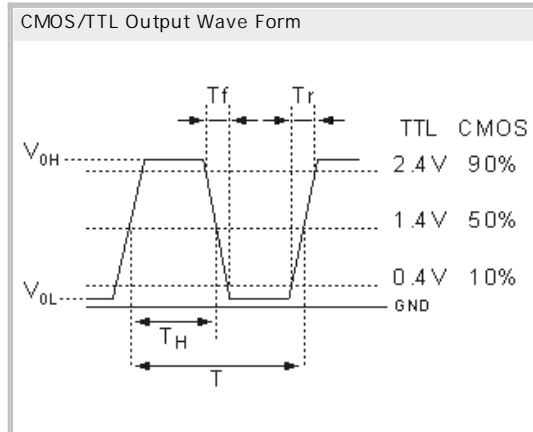
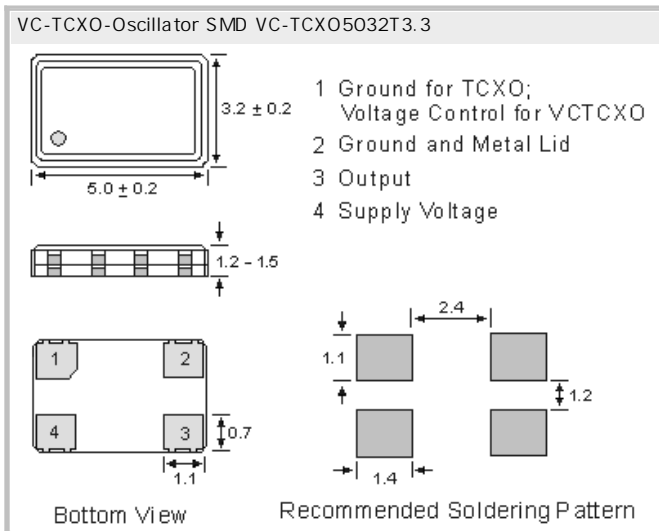

Specifications - Product No. G01920000CQZUPV00NB

Holder Type:	(VC)-TCXO-Oscillator SMD (VC)-TCXO5032T3.3 3.3V CMOS/TTL
Frequency:	19.200000 MHz
Input Voltage:	+ 3.3V ± 10%
Frequency Stability:	± 0.5 ppm at 25°C
Freq. Stability vs Temperature:	± 0.5 ppm from -20°C to +70°C
Freq. Stability vs Aging:	± 1.0 ppm, first year at 25°C
Freq. Stability vs Voltage Change:	± 0.3 ppm, for a ± 5% input voltage change
Freq. Stability vs Load Change:	± 0.3 ppm, for a ± 10% load condition change
Operating Temperature Range:	-20°C to +70°C
Maximum Supply Current:	6.0 mA max.
Output Load:	15pF
Output Logic Levels:	Logic High "1" : 90% V _{dd} min. // Logic Low "0" : 10% V _{dd} min.
Rise/Fall Time (10% to 90% V _{dd}):	10.0 nsec. max., 20% to 80% of the wave form
Voltage Control on pin 1 (EFC):	Electronic Frequency Tuning (EFC)
Pin 1 Options VCTCXO only (EFC):	Control Voltage: Standard +1.5V ± 1.0V for all input voltages. Slope Polarity: Positive slope. Positive voltage for positive frequency shift. Input Impedance: 50kOhm min.; Linearity ±10% max. Modulation Bandwidth (at-3 dB) : 20kHz min.
Frequency Deviation Range (EFC):	± 5.0ppm (min.) with V _{con} = +1.5V ± 1.0V
Output Symmetry (Duty Cycle):	45/55% ; Measured at 50% V _{dd}
Rise/Fall Time CMOS:	10.0ns (max.) 20% <-> 80% V _{dd} of the wave form
Start Up Time:	10 ms (max.), 5ms (typ.)
Integrated Phase Jitter:	1 ps max. (12 kHz to 20 MHz)
Phase Noise (10.00MHz 3.3V):	- 96dBc/Hz at 10Hz offset -122dBc/Hz at 100Hz offset -138dBc/Hz at 1kHz offset -145dBc/Hz at 10kHz offset -150dBc/Hz at 100kHz offset
Storage Temperature:	-55 to +105°C
Reflow Condition:	260°C max

GERMANY
 COMTEC CRYSTALS GmbH - Sultenstrasse 12-14
 8 5 5 8 6 P o i n g / G E R M A N Y
 Phone +49 8121 778160 · Fax +49 8121 778177
 e-Mail info@comtec-crystals.com
 Internet: <http://www.comtec-crystals.com>
 Subject to change without prior notice.



Technical Data and Graphics are all under
 Copyright (c) of Comtec Crystals Group.

FRANCE:
 COMTEC CRYSTALS SARL · 23, rue du Faucon
 6 7 5 0 0 H a g u e n a u / F R A N C E
 Phone +33 388 732162 · Fax +33 388 730118
 e-Mail sales@comtec-crystals.com
 Internet: <http://www.comtec-crystals.com>
 sous réserve de modifications.

